

CIRCUIT DIAGRAM

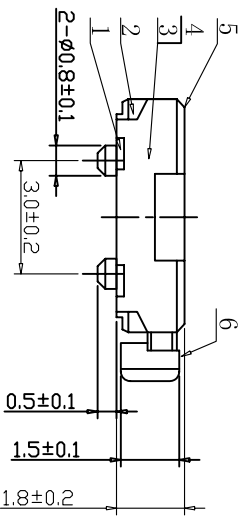

- SPECIFICATION**
1. RATING: DC 12V, 50mA
  2. OPERATING FORCE: 250 ± 50gf
  3. TRAVEL: 0. 25mm
  4. LIFE: 30, 000cycles
  5. PACKAGE: 3000Pcs/Reel

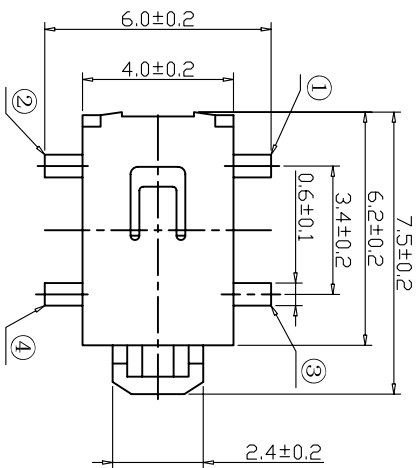
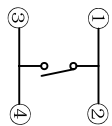
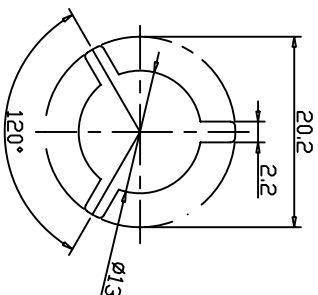
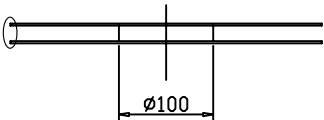
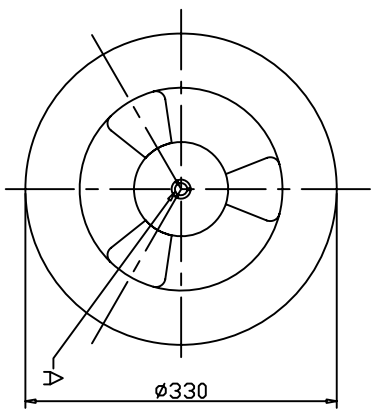
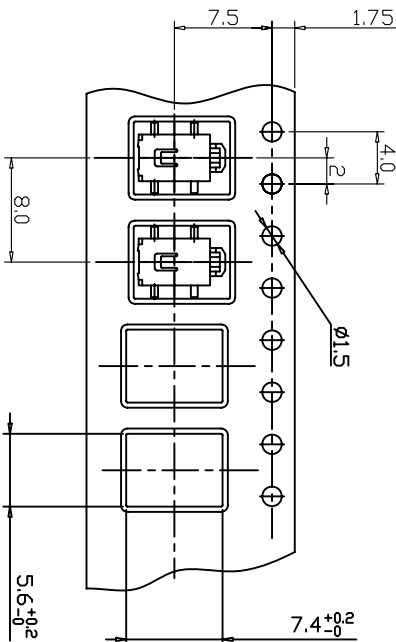
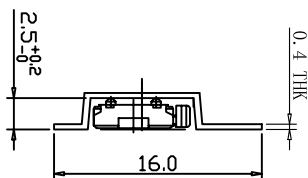
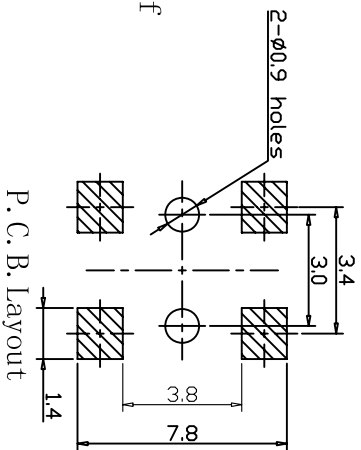

SCALE 1:10

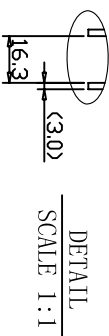

6	KNOB	PA6T	1	BLACK
5	COVER	STAINLESS STEEL	1	NATURAL
4	KAPTON	POLYAMIDE	1	YELLOW
3	CONTACT	STAINLESS STEEL	1	Ag-Plate
2	CASE	PA6T	1	WHITE
1	TERMINAL	BRASS	4	Ag-Plate
NO.	PARTS	MATERIALS	QTY	FINISH

TOLERANCES UNLESS OTHERWISE SPECIFIED WITHIN: 1.5mm ± 0.1mm OVER: 1.5mm ± 0.2mm

DRAWN / DATE: JIALIN CHEN 2012.02.08  
 CHECKED / DATE: DACAI GU 2012.02.08  
 APPROVED / DATE: GUANGMING DU 2012.02.08

TACT SWITCH

SCALE 1:1

UNIT mm

SHEET 1 / 1

MODEL

TP-1113S1-DE1325

DWG. NO.



东一部品电子有限公司  
 TONE PARTS ELECTRONICS CO., LTD